

**TAMEO KITS**  
scale racing car models



**TMK 410**  
**FERRARI F2012**  
**G.P. GERMANIA/ITALIA 2012**  
**F. Alonso - F. Massa**  
**[www.tameokits.com](http://www.tameokits.com)**



## Colour conversion - Conversione colori - Farbenumwandlung Conversion de couleurs - Colores convensionados

BRIGHT MICA RED ROSSO VIVO METALLIZZATO HELLES MICA ROT ROUGE MICA VIF ROJO VIVAZ MICA	SILVER ARGENTO SILBER ARGENT PLATA	CLEAR RED ROSSO SEMITRASPARENTE HELLROT ROUGE CLAIRE ROJO CLARO	BRIGHT MICA RED ROSSO VIVO METALLIZZATO HELLES MICA ROT ROUGE MICA VIF ROJO VIVAZ MICA	METALLIC SILVERARGENTO METALLIZZATO METALLISERT SILBER ARGENT METALISE PLATA METALIZADA	CLEAR BLUE BLU SEMITRASPARENTE HELLBLAU BLEU CLAIRE AZUL CLARO	WHITE BIANCO WEISS BLANC BLANCO	MATT BLACK NERO OPACO MATTSCHWARZ NOIRE OPAQUE NEGRO OPACO	BUFF SANDFARBEN CHAMOIS ANTE
TAMIYA TS85	TAMIYA X11	TAMIYA X27	TAMIYA TS85	TAMIYA TS83	TAMIYA X23	TAMIYA TS26	TAMIYA TS6	TAMIYA XF57

## Photoetcheds - Fotoincisioni - Fotogaeetz Photogravures - Fotograbado

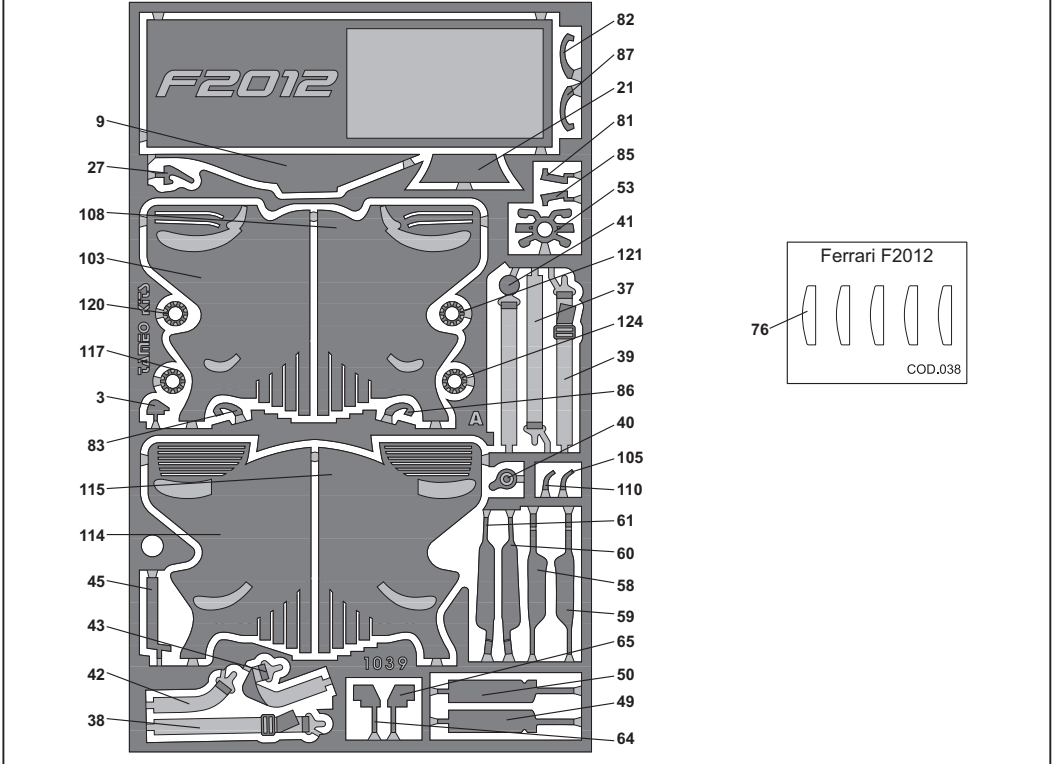

**FILO D' ACCIAIO**  
STEEL WIRE  
STAHLDRAHT  
FIL ACIER  
ALAMBRE D'ACERO

**FILO DI RAME**  
COPPER WIRE  
KUPFERDRAHT  
FIL CUIVRE  
ALAMBRE DE COBRERO

**FILO DI NYLON**  
NYLON WIRE  
NYLONDRAHT  
FIL DE NYLON  
ALAMBRE DE NYLON

**LUNGHEZZA**  
LENGTH  
LAENGE  
LONGUEUR  
LARGO

**DIAMETRO**  
DIAMETER  
DURCHMESSER  
DIAMETRE  
DIAMETRO

**NON COLORARE**  
NO PAINT  
KEINE FARBE  
PAS DE PEINTURE  
SIN PINTURA

**PIEGARE**  
TO BEND  
BIEGEN  
PLIER  
DOBLAR

**PEZZI** GLUE AND STICK BEFORE PAINTING  
**PARTS** INCOLLARE E STUCARE PRIMA DELLA VERNICIATURA  
**STUECKE** VOR DER LACKIERUNG VERKLEBEN UND VERSPACHTELN  
**PIEZAS** COLLER ET MASTIQUER AVANT DE VERNIR  
PEGAR Y ESTUCAR ANTES DE PINTAR

**USE PROFILE "A" ON PHOTOETCHED #1033 TO BEND PARTS 28-29**  
usare il profilo "A" sulla fotoincisione #1033 per piegare parti 28-29  
**wenden sie profile "A" ueber fotogaeetz #1033 fuer teilen 28-29 falten**  
employez le passepoil "A" sur la photogravures #1033 pour plier pieces 28-29  
utilice el contorno "A" sobre el fotograbado #1033 por doblar piezas 28-29



**TAMEO KITS** srl

Via Valle, 111 - P.O. Box 61  
17022 BORGIO VEREZZI SV ITALY  
Tel. 39 019 - 615.250 Fax. 39 019 - 615.310

website [www.tameokits.com](http://www.tameokits.com)  
e-mail [sales@tameokits.com](mailto:sales@tameokits.com)  
e-mail [technical@tameokits.com](mailto:technical@tameokits.com)



Produced under license of Ferrari SpA.  
FERRARI, the PRANCING HORSE device, all associated logos and distinctive designs are property of Ferrari SpA.  
The body designs of the Ferrari cars are protected as Ferrari property under design, trademark and trade dress regulations

Made in Italy. Modello per collezionisti in scala 1/43. Vietata la vendita ai minori di 14 anni. Nocivo per ingestione. Conservare fuori dalla portata dei bambini. Tameo Kits declina ogni responsabilità per un uso improprio del prodotto.

Made in Italy. Collector 1/43 Scale Models. Not for sale to persons under 14 years of age. Dangerous if swallowed. Keep out of reach of children. Tameo Kits not held responsible for any damage or injury resulting from improper use of the product.

Made in Italy. Modèle pour collectionneurs échelle 1/43. Vente interdite aux enfants de moins de 14 ans. Dangereux si avalé. Conserver hors de la portée des enfants. Tameo Kits décline toute responsabilité dans le cas de dommages dérivants de l'usage non approprié du produit.

Made in Italy. Sammlermodell im Masstab 1/43. Verkauf an Jugendliche unter 14 Jahren verboten. Schädlich bei Verschlucken. Tameo Kits lehnt jede Verantwortung bei unsachgemässer Benutzung des Produktes ab.

Hecho en Italia. Colección de modelos a escala 1/43. Prohibida la venta a menores de 14 años. No comestible. Mantener fuera del alcance e de los niños. Tameo Kits no se hace responsable de los daños causados por el uso incorrecto de este producto.

**1** GLUE AND STICK BEFORE PAINTING

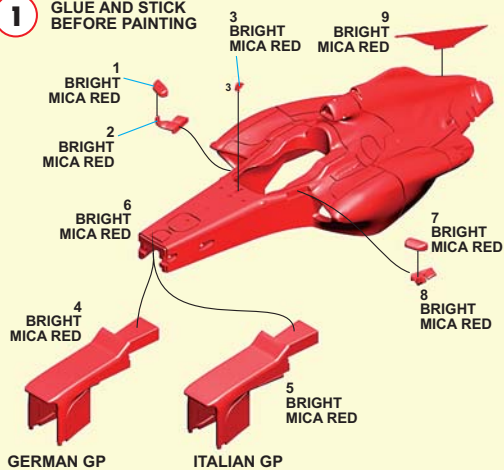

**2**

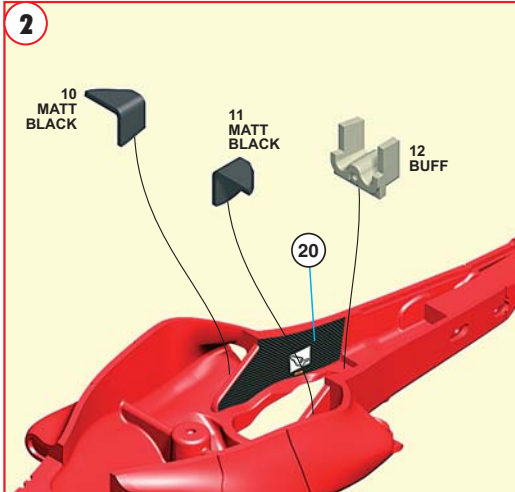

**GERMAN GP**



**3**

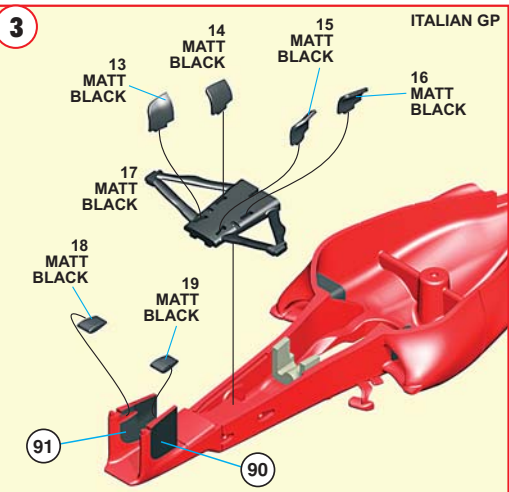

**4**

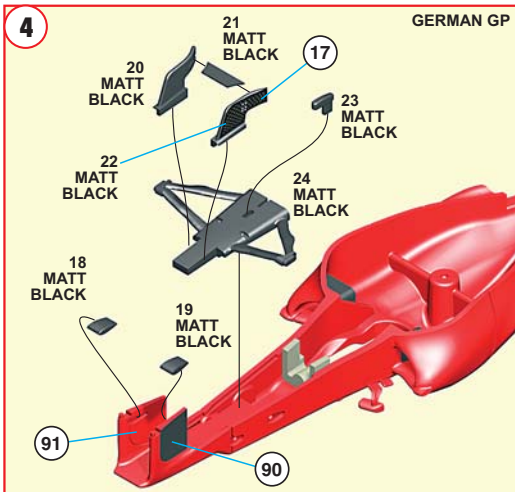



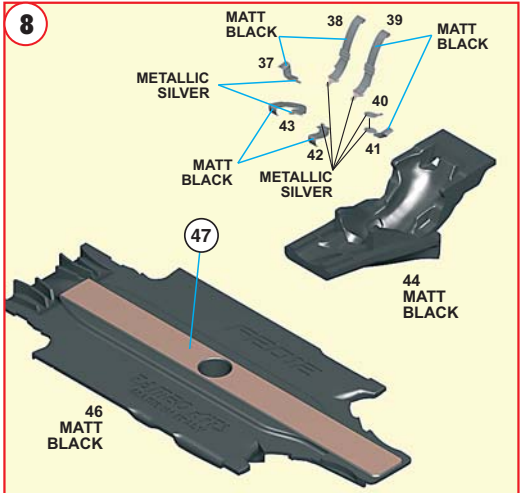
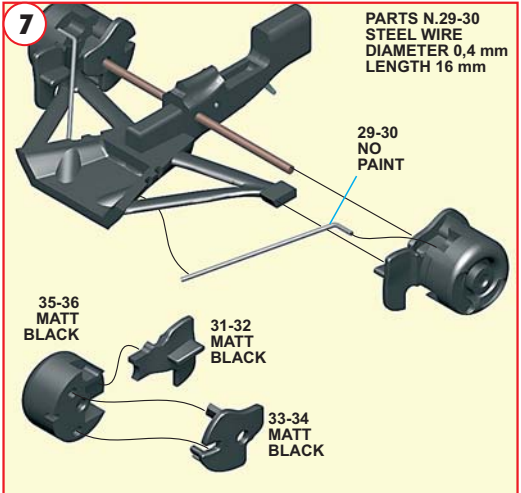
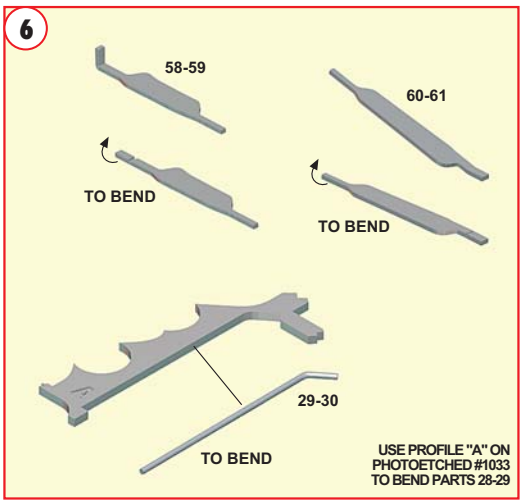
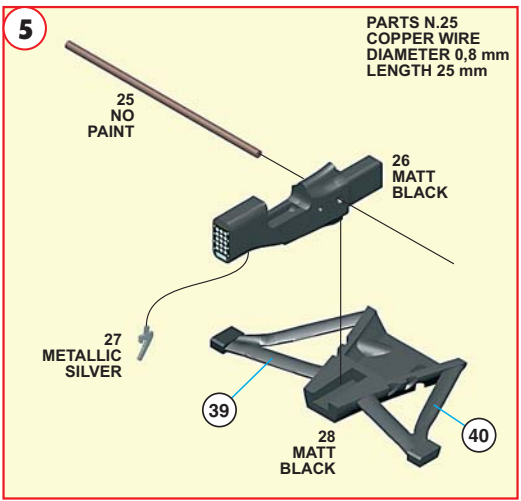

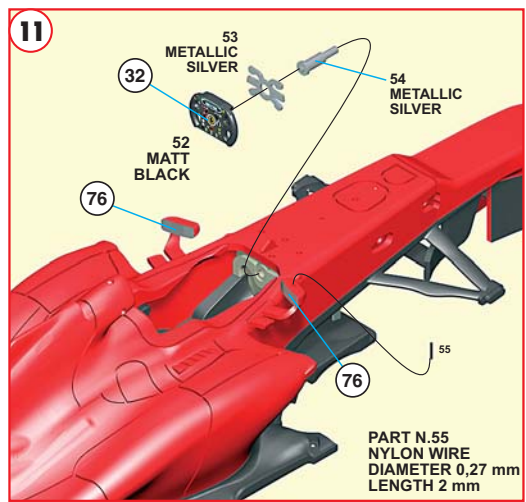
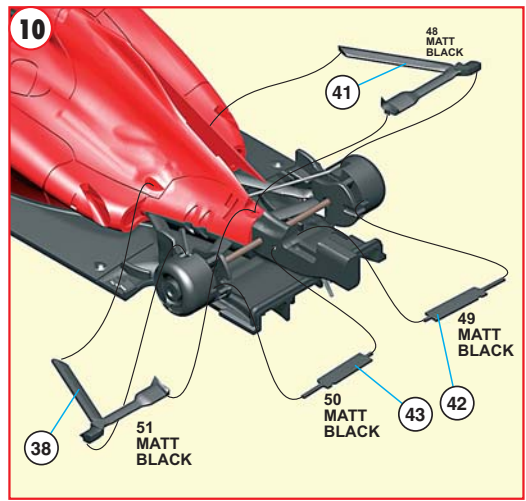
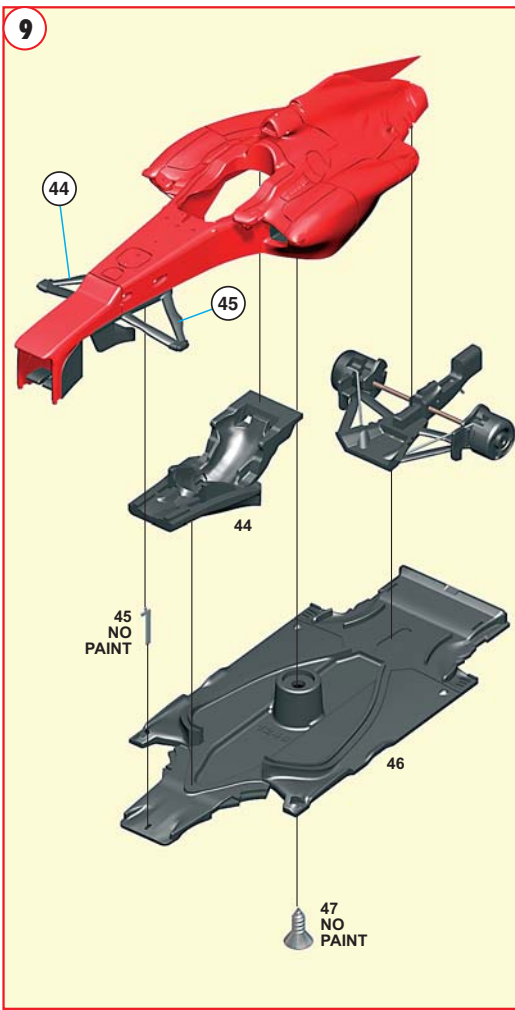

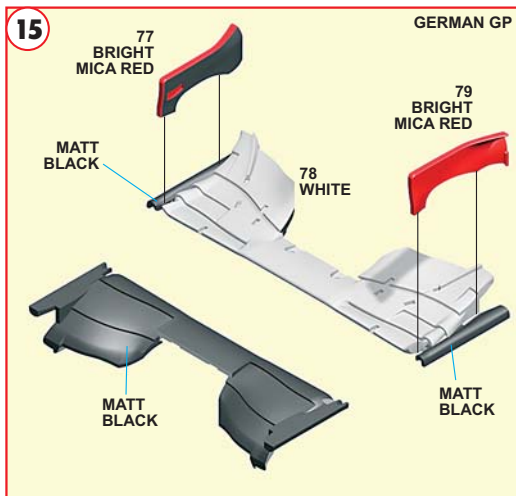
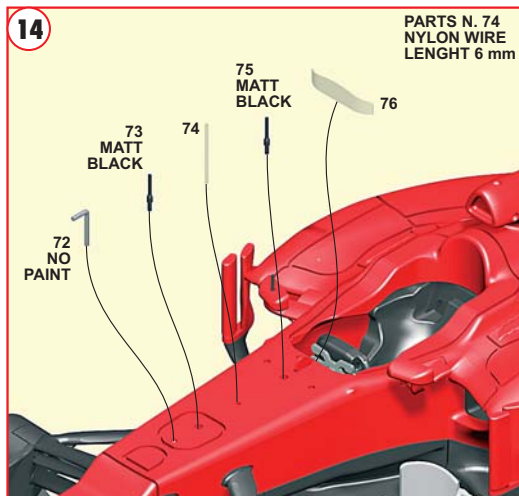
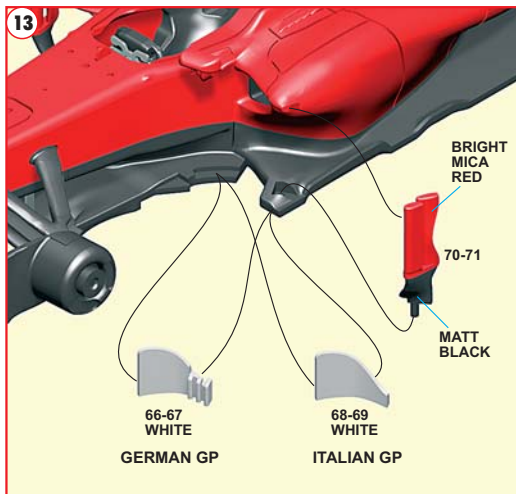
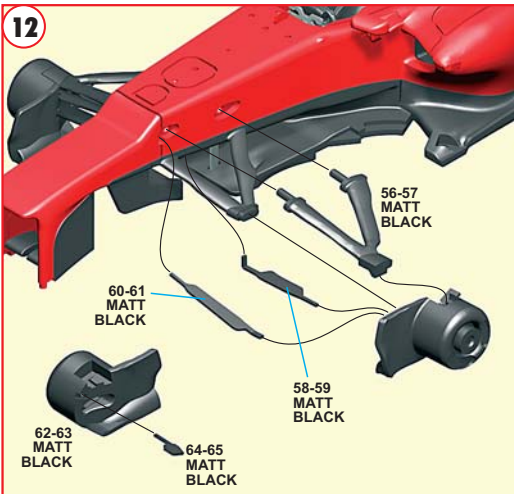



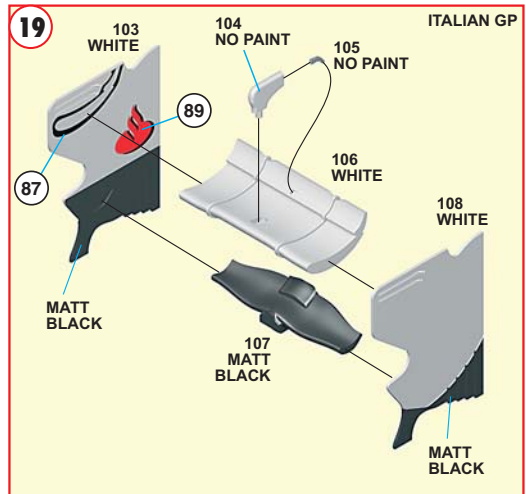
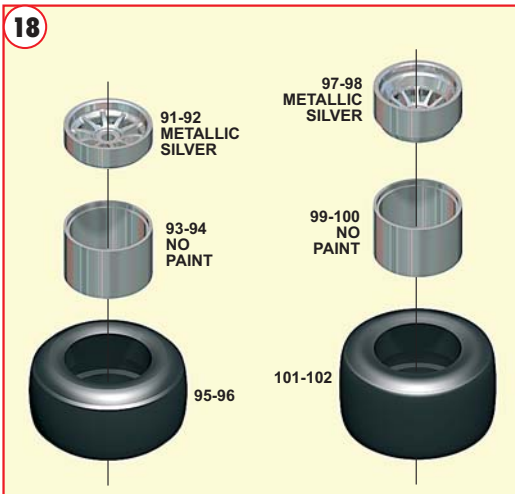
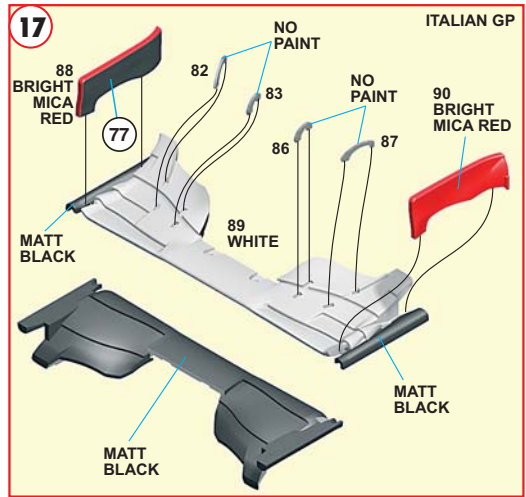
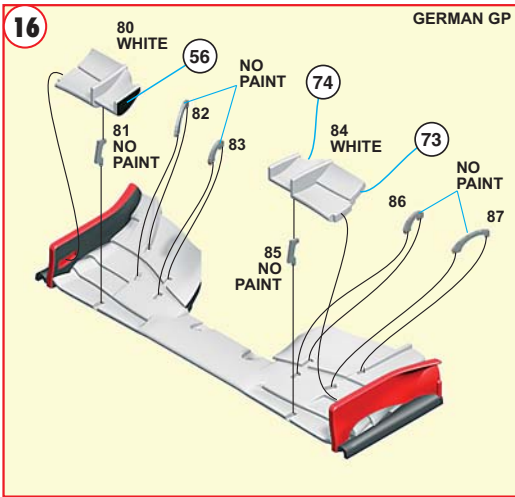

20

GERMAN GP

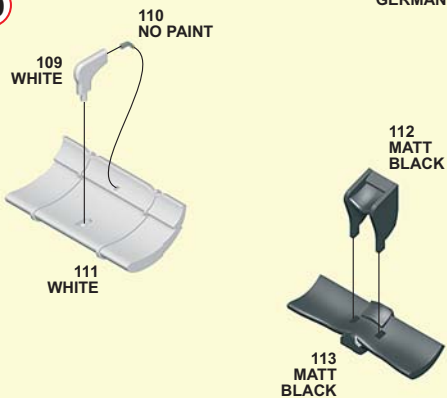

21

GERMAN GP

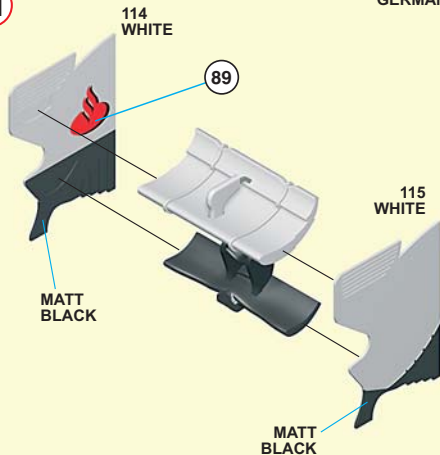

22

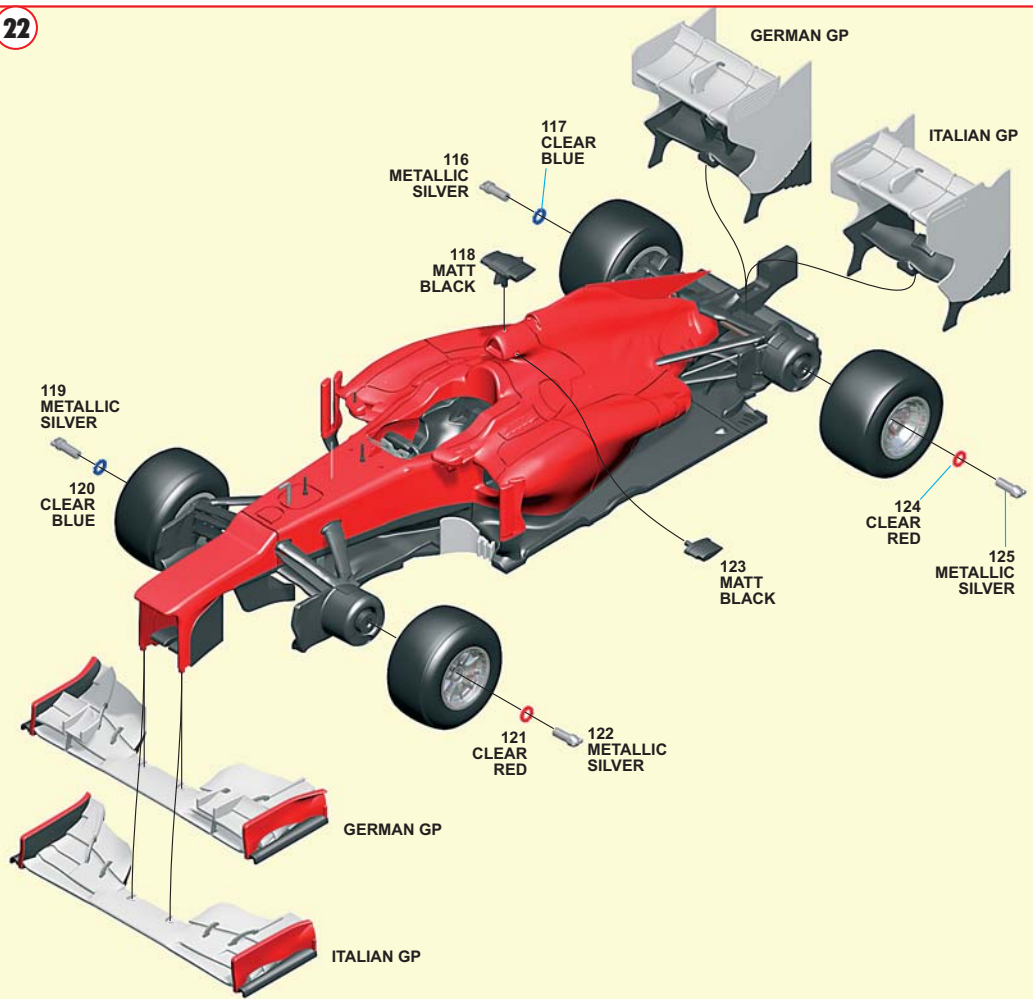



# TMK 410 FERRARI F2012 G.P. GERMANIA 2012

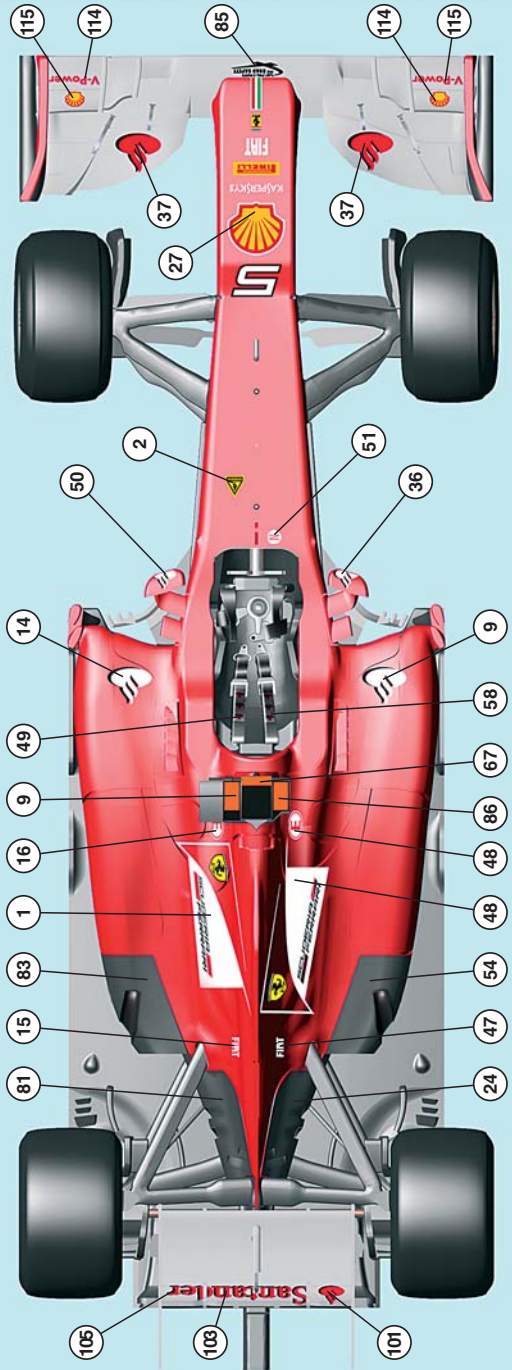
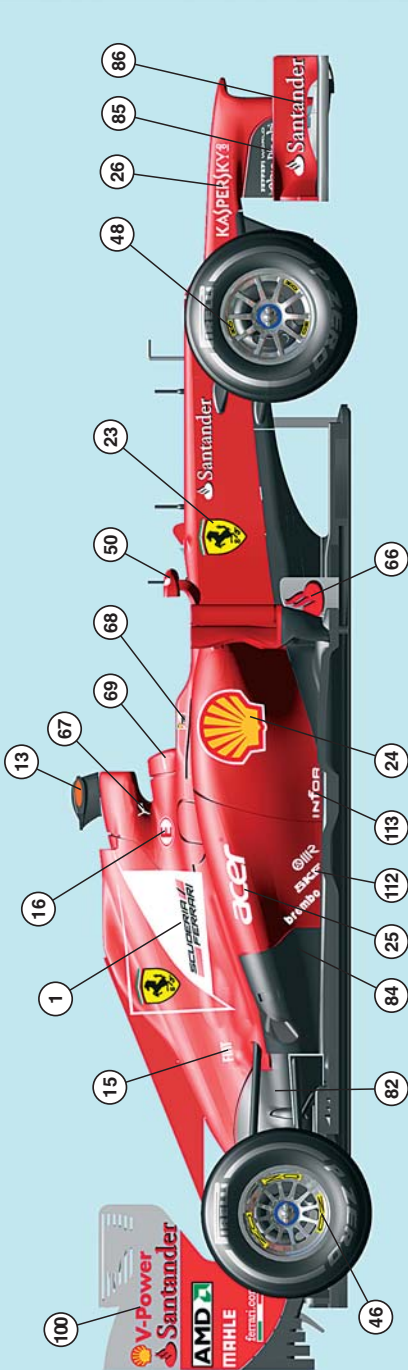

5 - F. Alonso 1st



6 - F. Massa 12th

# TMK 410 FERRARI F2012 G.P. ITALIA 2012

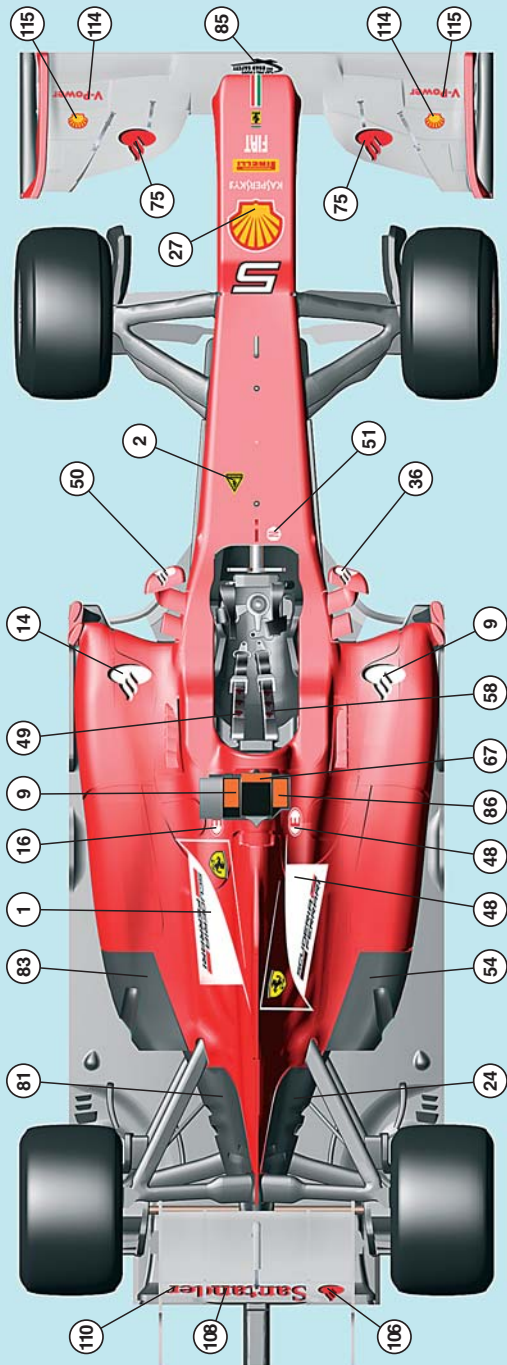
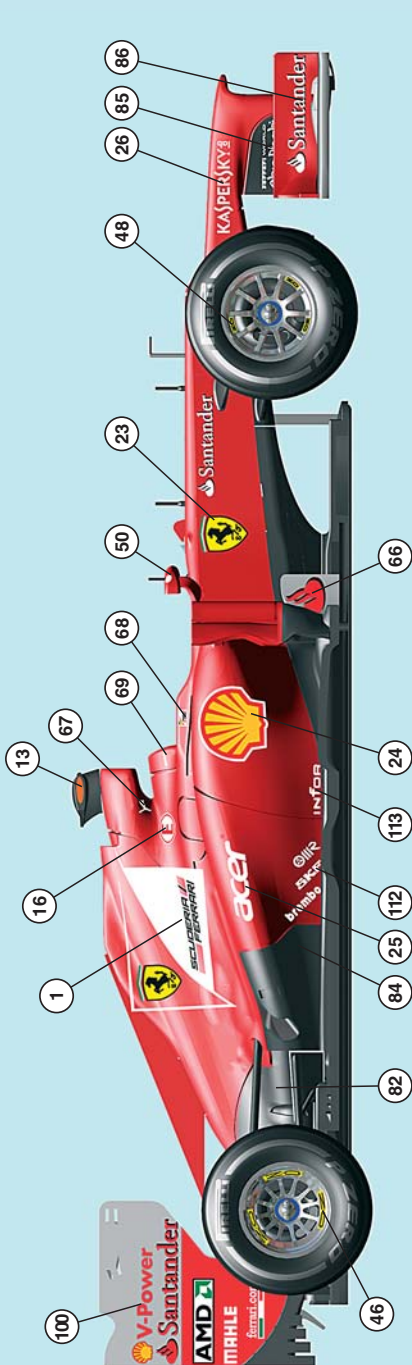

5 - F. Alonso 3rd



6 - F. Massa 4th



ITALIAN GP



ITALIAN GP



GERMAN GP





GERMAN GP



GERMAN GP



ITALIAN GP

